

# gm1601

## Single-Chip WUXGA Display Controller

### APPLICATION

- Multimedia LCD Monitors
- LCD TVs

### FEATURES

- Advanced Scaling
- MADi & LADI Video Processing
- Analog/DVI/Digital Video Input Ports
- Picture-in-Picture
- RealColor™ Technology
- On-Chip Microprocessor
- Integrated OSD Controller
- Dual LVDS Transmitters
- Auto Detection & Configuration
- Full Frame Rate Conversion

### PACKAGE

- 416 PBGA

### DESCRIPTION

The Genesis Microchip gm1601 display controller is a fully-integrated single-chip solution for multimedia LCD monitors and LCD televisions supporting resolutions up to WUXGA (1920 x 1200). The stand-alone system-on-a-chip design enables simplicity of design and rapid system development. Dual-channel TTL and dual LVDS transmitters allow direct connection to LCD modules.

This integrated solution includes industry-leading motion adaptive de-interlacing (MADi) and low angle directional interpolation (LADI) to optimize TV playback quality. The integrated Analog Digital Converter, Ultra-Reliable DVI™ receivers, and frame rate conversion ensure proven PC graphics compatibility. Integrated Picture-in-Picture, HDTV input support, and RealColor™ video-specific color controls enable HDTV-ready solutions. An embedded microprocessor and a versatile OSD engine facilitate rapid development of a reliable and attractive product.

The gm1601 is available in two versions (gm1601-BD and gm1601-CF); both versions come in standard or HDCP enabled configurations. The gm1601-CF version is backwards-compatible with the gm1601-BD version and incorporates some functional and quality improvements. The gm1601-CF version adds:

- MPEG noise reduction
- 4DQS electrical interface
- Adaptive contrast control
- 4MB addressable external parallel ROM interface

### gm1601 SYSTEM DIAGRAM

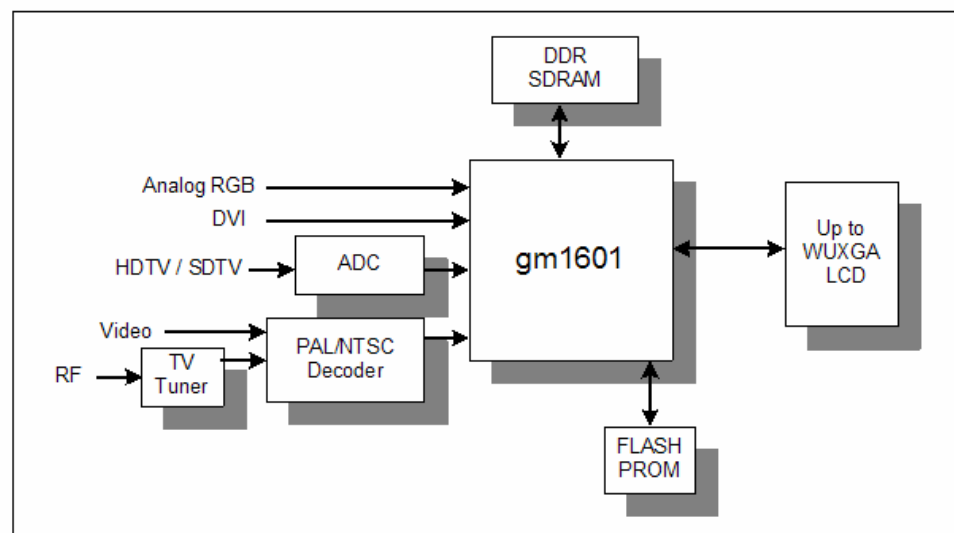

## gm1601 FUNCTIONAL BLOCK DIAGRAM

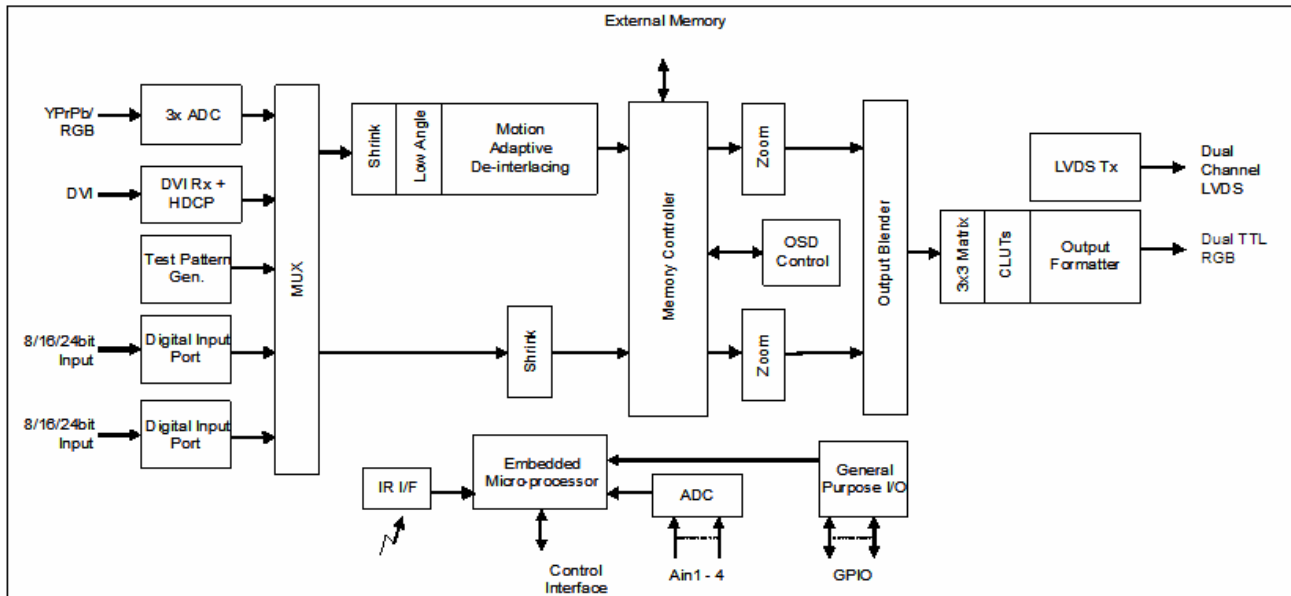

## FEATURE ATTRIBUTES

### HIGH-QUALITY ADVANCED SCALING

- Fully programmable zoom and shrink ratios
- Moire cancellation
- Non-linear scaling for aspect ratio conversion of video

### INDUSTRY LEADING VIDEO PROCESSING

- Motion Adaptive De-Interlacing (MADi) up to 1080i input on a per pixel basis
- Motion Adaptive and MPEG\* Noise Reduction functionality
- Inverse 3:2/2:2 pull down for Film Mode detection
- Low Angle Diagonal Interpolation (LADI)

### ANALOG RGB INPUT PORT

- Supports up to WUXGA at 60Hz (165 MHz)
- Captures RGB and Component YPbPr

### ULTRA-RELIABLE DVI COMPLIANT INPUT PORT

- Supports up to WUXGA at 60Hz (165 MHz)
- Direct connect to all DVI compliant digital transmitters
- High-bandwidth Digital Content Protection (HDCP)

### DIGITAL VIDEO/GRAPHICS INPUT PORT

- 4:4:4/4:2:2/CCIR656/601 8/16/24 bit digital video input port
- Additional CCIR656 digital video input port
- Accepts video and graphics data Anamorphic scaling (non-linear)

### AUTO-CONFIGURATION/AUTO-DETECTION

- Input format detection
- Phase and image positioning

\* Only available on the gm1601-CF version

### PICTURE-IN-PICTURE (PiP)

- Arbitrary window size
- Video PiP on Graphics/Graphics PiP on Video
- Side-by-side window support
- 4:3 to 16:10 aspect ratio support

### FRAME RATE CONVERSION AND INTERFACE

- Full frame rate conversion
- 32-bit wide data path to support standard 2Mx32/4Mx32 and 8Mx32 DDR SDRAM
- 1DQS and 4DQS\* electrical interface

### REALCOLOR™ TECHNOLOGY

- Digital brightness and contrast controls (adaptive contrast\*)
- TV color controls including hue and saturation controls
- Flesh-tone adjustment
- sRGB compliance allows end users to experience the same colors as viewed on CRTs and other displays

### ON-CHIP MICROPROCESSOR

- Requires no external microprocessor
- External parallel ROM interface. 1MB (UXGA)/4MB\* addressability
- General-purpose inputs/outputs (GPIOs) available for managing system devices (keypad, backlight, NVRAM, etc)

### ADVANCED ON-CHIP OSD CONTROLLER

- 12 True color bitmap tiles
- 1, 2, 4 and 8-bit per pixel
- Horizontal and vertical stretch of OSD menus
- Blinking, transparency, and blending